

Installation Instructions for 8905 Series Omni Trilock

Single Pull Handle Version - Suits 35mm to 45mm door thickness

Step 1.

- Fold template where indicated.
- Position template on door edge at desired lock / latch height.
- Firmly hold template and mark latch height and 2 off 60mm holes centres.
- Measure door thickness and mark centre on 'latch height' marking.
- Drill 22mm (7/8") latch hole.

Note: it is important to drill this hole squarely.
 • Drill pilot holes [suggested size 3mm (1/8")]. Then enlarge holes to 60mm, drilling from both sides of the door.

In particular, ensure the 60mm dia. holes through door face are drilled only to this size, otherwise correct functioning may be impeded – refer template.

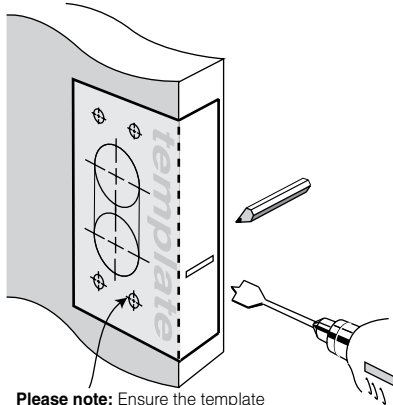

Please note: Ensure the template position and orientation is as shown, incorrect installation voids warranty.

Step 2.

- Mark vertical lines between two holes as per illustration.
- Cut along marked lines

Mark vertical lines between holes as shown. Cut along vertical lines

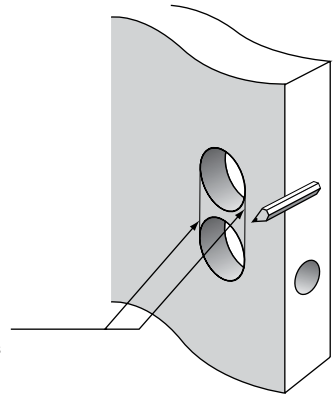

Step 3.

- Mark and chisel latch faceplate to a recess of 2.5mm. Use latch carrier as a template.
- Insert lock body into 60mm (2 3/8") slot.
- Insert latch carrier through 22mm (7/8") hole into lock body assembly and tighten with 2 screws.

Ensure T-shaped hole at rear of latch carrier is upright!

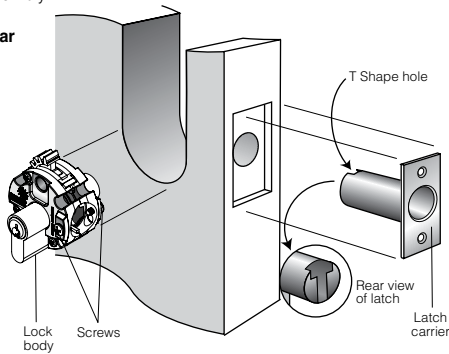

Step 4.

- Insert the latch through the slot in the carrier until it can go no further.
- Insert the key and turn to retract the latch bolt.
- Pre-drill wood screw holes with suitable drill size.
- Install plastic faceplate shim and faceplate, then screw into position.

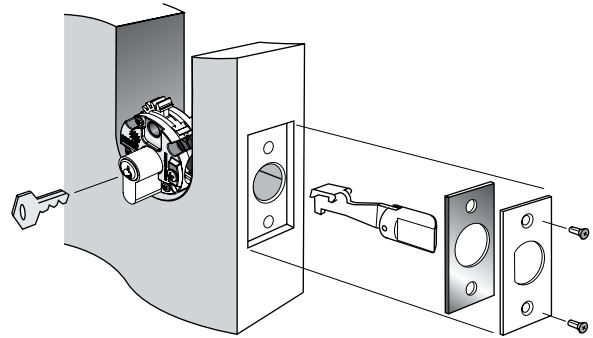

Step 4a

Trilock Latch Bolt re-handing.

- Check that tapered side of the Latch bolt faces towards the door jamb.
- It may be necessary to unclip the rear arm & rotate bolt 180°
- This is achieved by following steps:

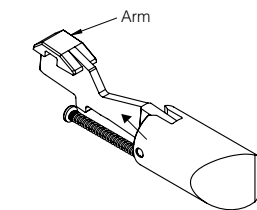

1. Remove Latch bolt assembly from carrier

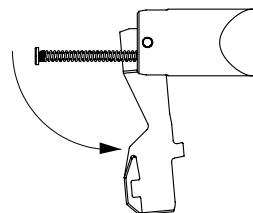

2. Rotate arm down wards

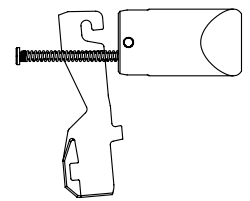

3. Unclip arm from latch bolt

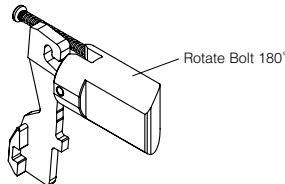

4. Rotate Bolt 180°

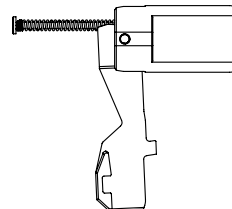

5. Re-attach arm to latch bolt

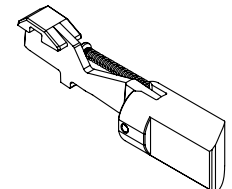

6. Rotate arm up wards & fit back into carrier

NOTE:

- carefully follow these instructions when installing.
- do not overtighten screws.
- use of power driver is not recommended.
- fully remove the Trilock prior to painting the door to avoid harming the product's finish.

Installation Instructions for 8905 Series Omni Trilock

Single Pull Handle Version - Suits 35mm to 45mm door thickness

Step 5

- Remove perforated cut-out from card-board template and place over lock body, making sure template is square to door edge.
- While holding template firmly in position, mark remaining 4 holes, as indicated on both sides of the door (reversing template as required).
- Drill pilot holes from both sides of the door [suggested size 3mm (1/8")] then enlarge, again from both sides of the door, to sizes indicated on template, otherwise correct functioning may be impeded – refer template.

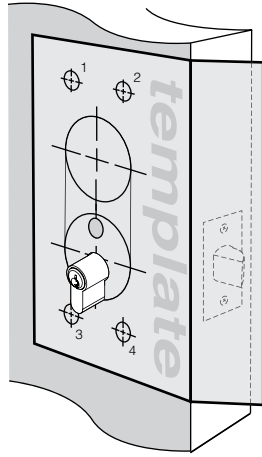

Step 6

To rehand internal lever & set lever operation (if required).

- Hold Trilock faceplate up to door to check lever orientation.
- To rehand lever, if required, insert flat blade screwdriver under handing-plate and twist.
- Rotate lever 180° toward top of faceplate, as shown, until it clicks into place.

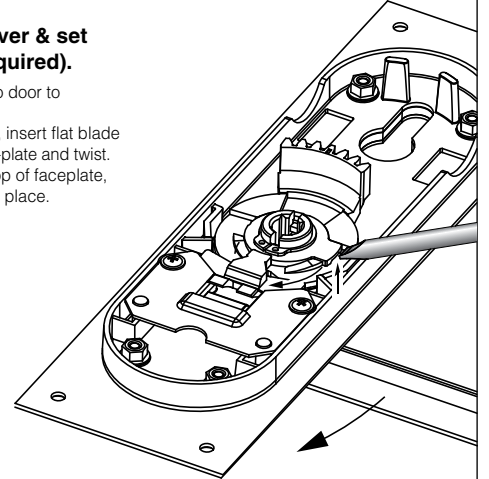

Step 7

To rehand external lever & set lever operation (if required).

- If rehanding is required remove the stop screw from SS1 & fit to SS2, to allow Lever to operate away from door edge

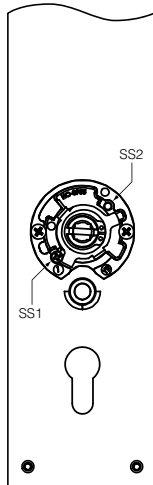

Step 8.

- Install 4 posts to Trilock external faceplate (this is the faceplate **without** the rectangular snib push-button).

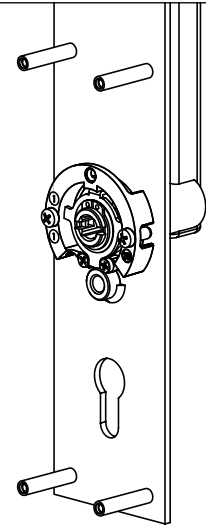

Step 9

- Mount the Inside face plate so that mark on large gear engages with mark on lock bodygear

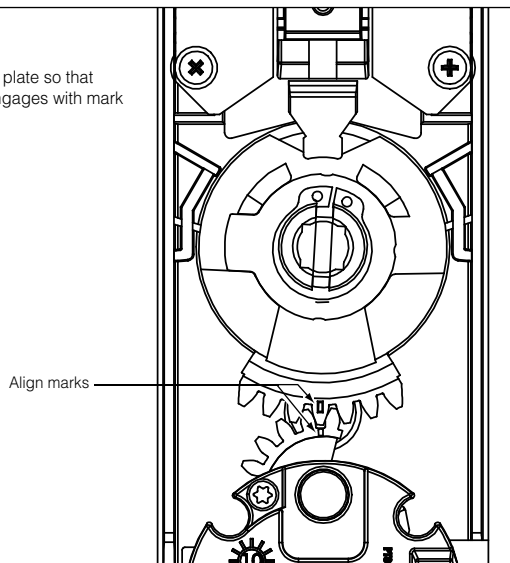

NOTE:

- carefully follow these instructions when installing.
- do not overtighten screws.
- use of power driver is not recommended.
- fully remove the Trilock prior to painting the door to avoid harming the product's finish.

Gainsborough
ENTER WITH STYLE™

3 IN 1 FUNCTION
TRILOCK™
DEADBOLT | LOCKSET | PASSAGE SET
OMNI SERIES

Installation Instructions for 8905 Series Omni Trilock

Single Pull Handle Version - Suits 35mm to 45mm door thickness

Step 10

- Insert spring and snib rotor in the square hole of the internal lever.
- Position snib rotor so one notch faces up and the other notch points to the latch side.
- Mount outside faceplate to outside of the door, and align the two making sure the snib rotor engages with the external lever.
- Fit mounting screws from inside and tighten into threaded posts.

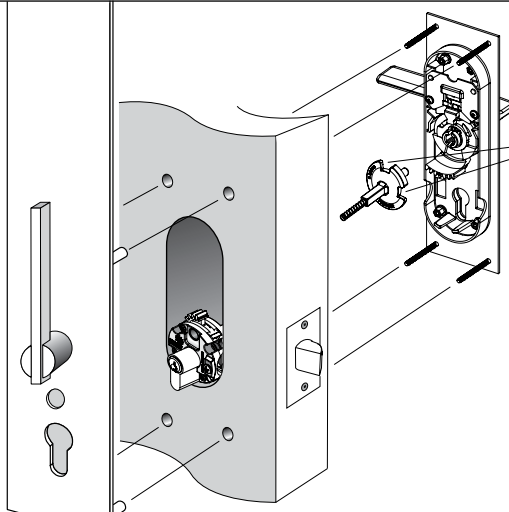

Note: Position Snib Rotor so one notch faces up & the other notch points to the door edge.

NOTE: Test all functions for smooth operation.

Step 11

- For single cylinder applications install internal turnbutton now by tightening grub-screw onto protruding shaft.

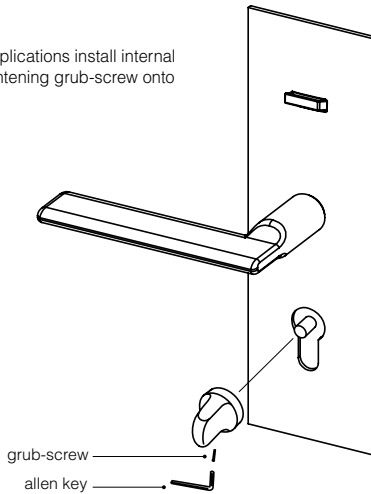

Step 12

All door seals must be fitted prior to fitting strike plate.

- Position the door so that the centrepoint of the strike plate can be marked on door frame.

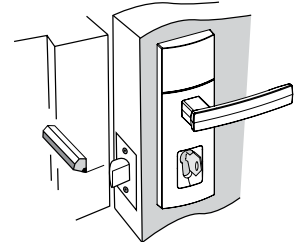

- Mark and drill a 25mm (1") hole to a depth of 25mm (1"), at a corresponding height to the bolt.
 - Mark and chisel recesses for strike plate and optional reinforced strike plate.
 - Screw into position using 4 wood screws as supplied.
- Note:** 2 larger screws should be used on reinforced strike plate as illustrated.

Door Adjustment

- 1 When door is closed using finger pressure, ensure bolt is latching into strike plate.
- 2 If door is rattling when in latched position. Open door, remove strike plate & adjust anti-rattle tab & refit strike plate to door frame. Repeat check 1.

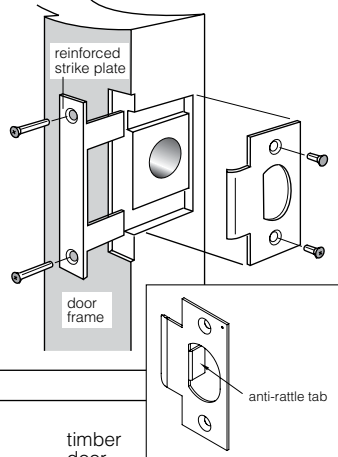

Step 13

Fixing of single pull handle

Note: Suitable for solid doors only

- Check and make sure that the outside faceplate is lined up straight and square with the door.
- Once the desired position of the outside faceplate has been confirmed, mark the centre of the hole at the top of the faceplate and proceed to drill a suitable hole.
- Note: When drilling the hole drill to a suitable depth ONLY to accommodate the coach screw (**DO NOT DRILL ALL THE WAY THROUGH THE DOOR**).
- On the side requiring the pull handle, hold the optional rectangular plastic washer centred over the hole against the door surface.
- Hold the threaded bush onto the outside faceplate, ensuring the larger section of the bush, as marked 'A' in illustration, is facing the door.
- From the same side, install the 1/4" diameter coach screw through the threaded bush and optional plastic washer (if used) and into the door.
- Tighten coach screw securely with spanner.
- Place the pull handle over top of 2 mounting bushes.
- Line up the pull handle so that it is lined up straight and square. Insert the grub screws and tighten with allen key provided

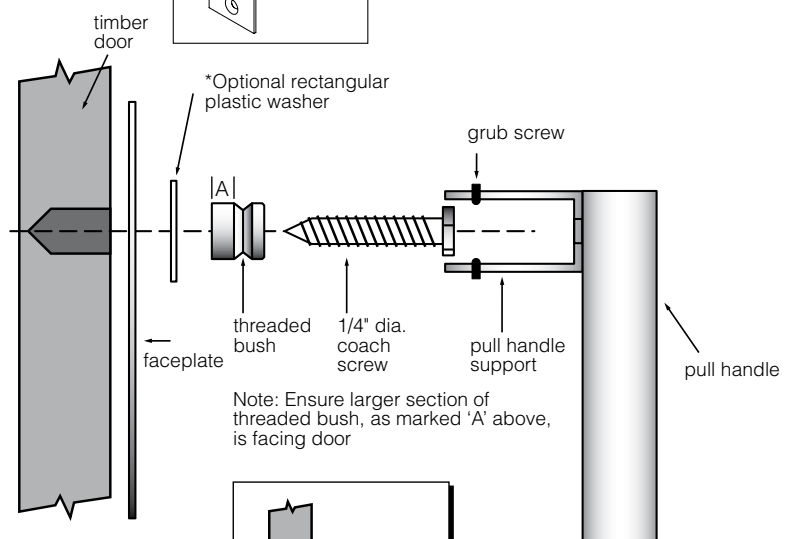

Note: Ensure larger section of threaded bush, as marked 'A' above, is facing door

- NOTE:**
- carefully follow these instructions when installing.
 - do not overtighten screws.
 - use of power driver is not recommended.
 - fully remove the Trilock prior to painting the door to avoid harming the product's finish.

Gainsborough
ENTER WITH STYLE™

3 IN 1 FUNCTION
TRILOCK™
DEADBOLT | LOCKSET | PASSAGE SET
OMNI SERIES

Installation Instructions for 8905 Series Omni Trilock

Single Pull Handle Version - Suits 35mm to 45mm door thickness

Exploded Diagram

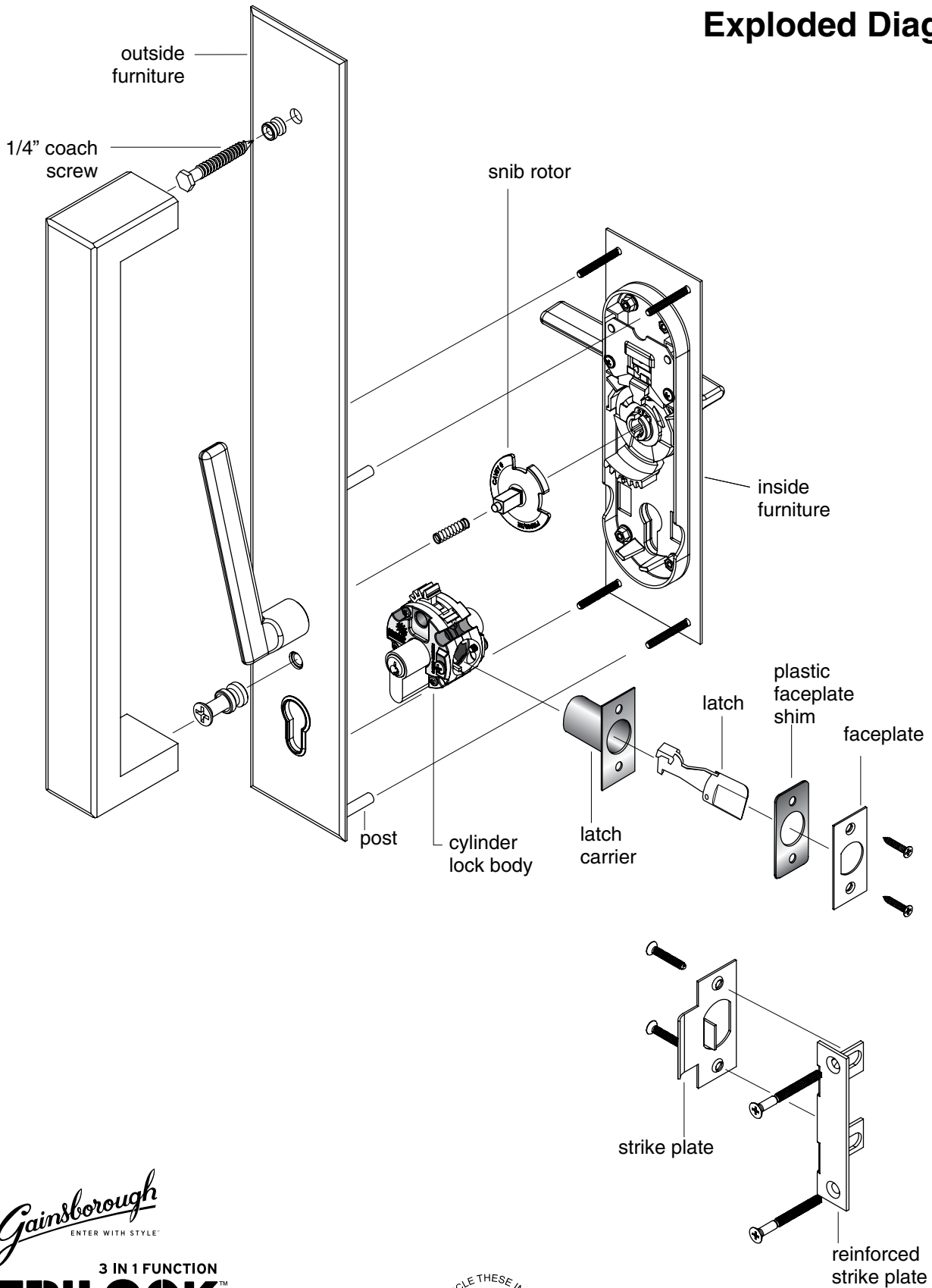

Gainsborough
ENTER WITH STYLE™

3 IN 1 FUNCTION
TRILOCK™
DEADBOLT | LOCKSET | PASSAGE SET
OMNI SERIES

